

Features:

- 10 ports optical switch:
 8 SFP ports 1000 Mb/s
 2 ports 10/100/1000 Mb/s RJ45
- Supports auto-learning and auto-aging of MAC addresses (8K size)
- Built-in switch mode power supply PSD12020 12 V DC
- Additional mounting elements
- LED indication
- warranty – 2 years from production date

Example of use.

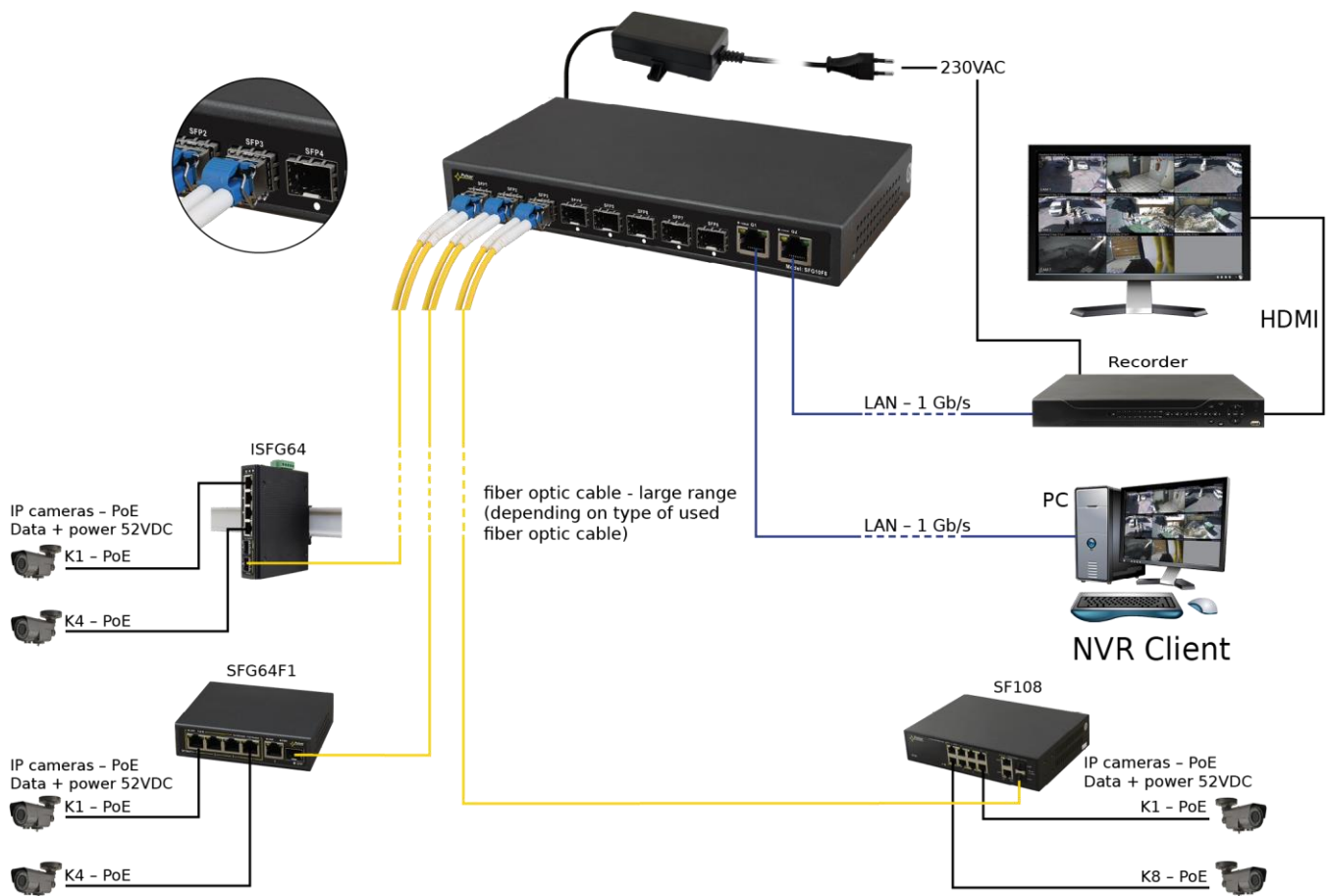

1. Technical description

1.1. General description.

SFG10F8 is 10-port optical switch designed for data transmission over Ethernet via fiber optics and UTP cables. Cat 5e. Switch has 8 SFP sockets (marked SFP1 ÷ SFP8), which after using SFP modules (GBICs) enable fiber optic transmission. G1 and G2 ports are used to connect further network devices through RJ45 socket. The LEDs at the front panel indicate the operation status (description in the table below).

Connectivity via fiber optics cables allows for fast and stable data transmission over long distances, resistant to electromagnetic interference and adverse environmental conditions. It also enables easy expansion of network in future.

1.2 Block diagram.

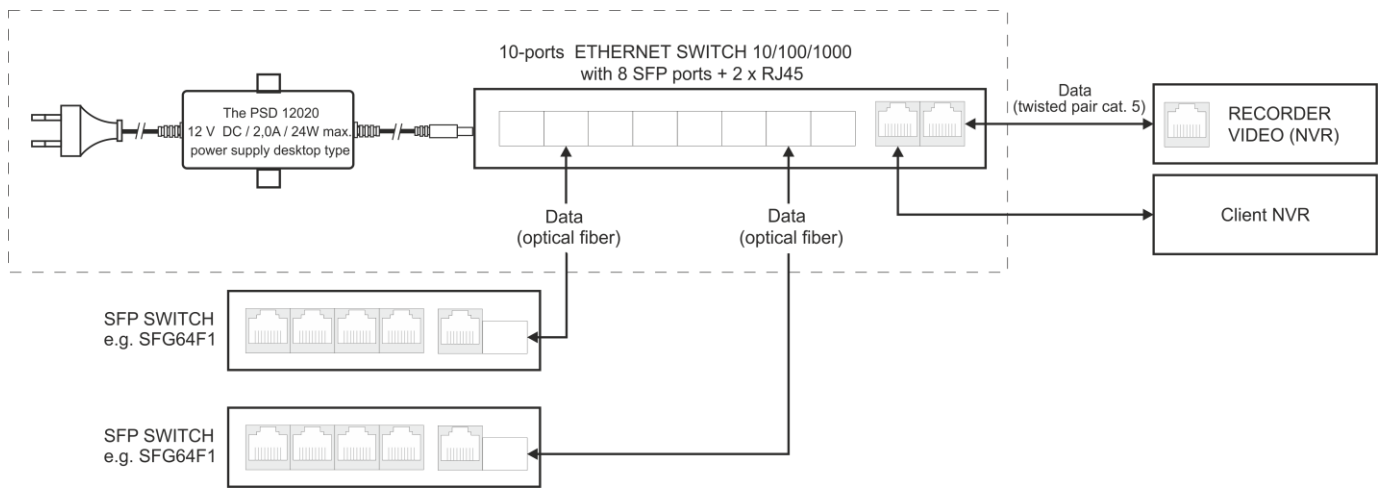

Fig. 1. Block diagram.

1.3. Description of components and connectors.

Table 1. (see Fig.2)

Element no. (Fig. 2)	Description
[1]	2 x RJ45 ports
[2]	8 x SFP ports (1÷8)
[3]	DC power supply socket
[4]	Additional mounting elements

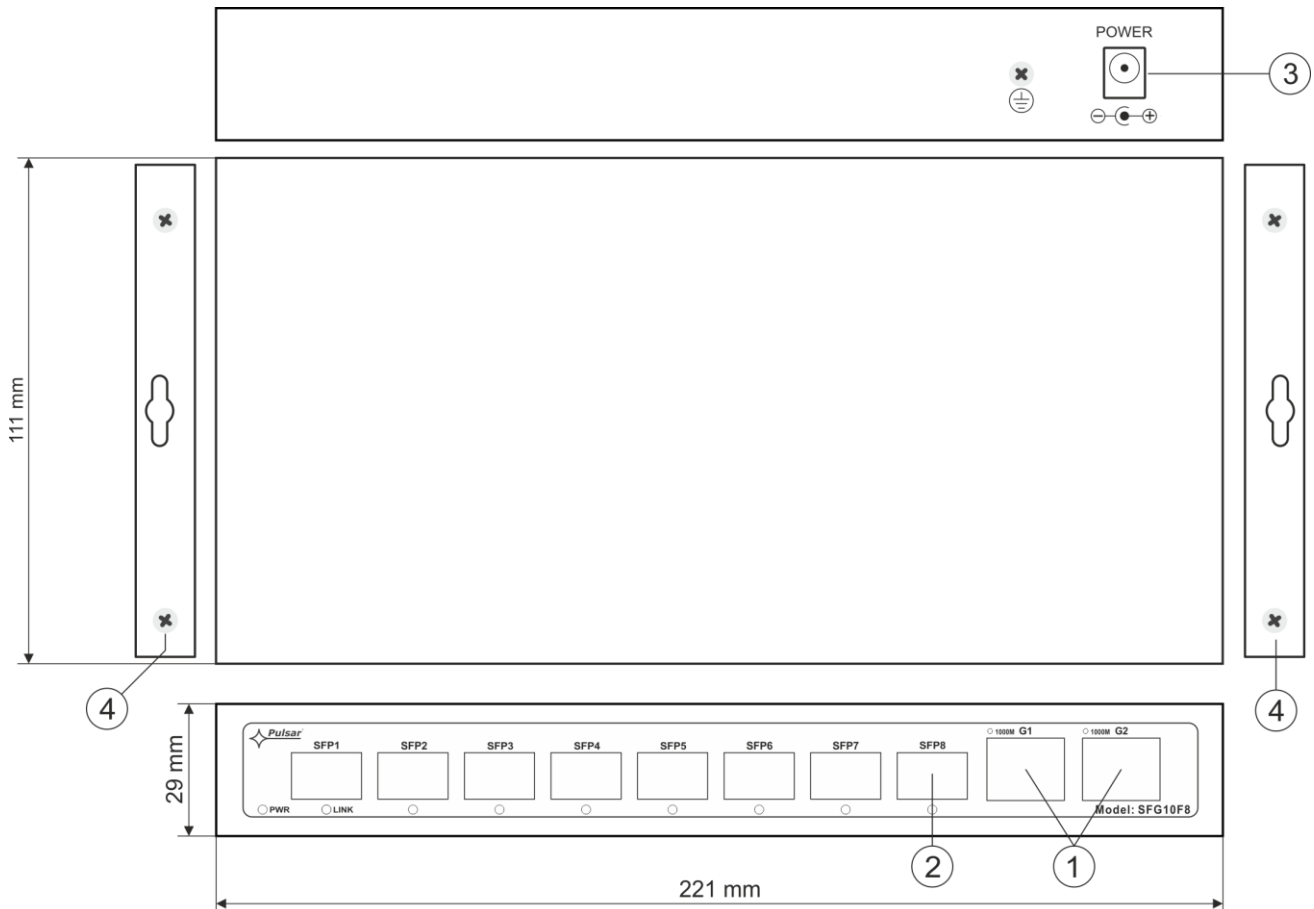

Fig. 2. The enclosure view.

1.4. Technical parameters.

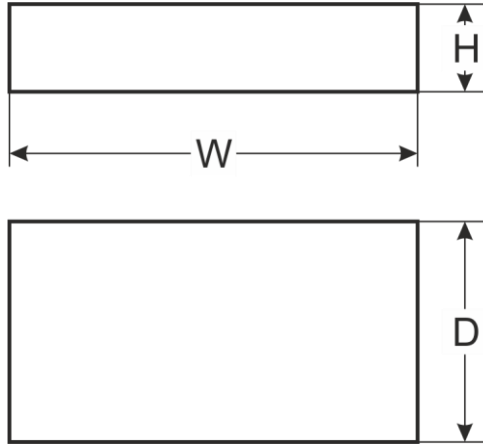

Table 2.

Ports	10 ports (8 x SFP + 2 x RJ45) 8 x 1000 Mb/s (SFP) 2 x 10/100/1000 Mb/s (RJ45) with connection speed auto-negotiation and MDI/MDIX Auto Cross
Protocols, Standards	IEEE802.3i, 802.3u, 802.3x CSMA/CD, TCP/IP
Bandwidth	16 Gb/s
Transmission method	Store-and-Forward
Optical indication of operation	Switch power supply; Link/Act;
Power supply	~100-240 V; 50/60 Hz; 0,3 A switched mode power supply PSD12020 12 V DC / 2 A / 24 W max.
Operating conditions	Temperature: -10°C ÷ +40°C, relative humidity 20%...90%, without condensation
Dimensions	W=221, H=29, D=115 [+/- 2mm]
Additional equipment	surface mounting sheets
Net/gross weight	0,9 / 1,1 [kg]
Protection class EN 62368-1	II (second)
Storage temperatur	-20°C ÷ +60°C
Declarations	CE

2. Installation

2.1. Requirements

Unit should be mounted in confined spaces with normal relative humidity (RH=90% maximum, without condensing) and temperature from -10°C to +40°C. Ensure the free flow of air around the unit. The PSU shall work in a vertical position that guarantees sufficient convectional air-flow through ventilating holes of the enclosure.

The device is designed for a continuous operation and is not equipped with a power-switch. Therefore, an appropriate overload protection in the power supply circuit should be provided. The electrical system shall be made in accordance with applicable standards and regulations.

2.2. Installation procedure

1. Install GBIC's to SFP sockets.
2. Connect switch to the PSD12020 12 V DC power supply unit desktop type.
3. Connect the power supply to the 230 V socket.
4. Connect devices to G1, G2 ports.
5. Check the optical indication of the switch operation (see Table 3).

Connection schemes:

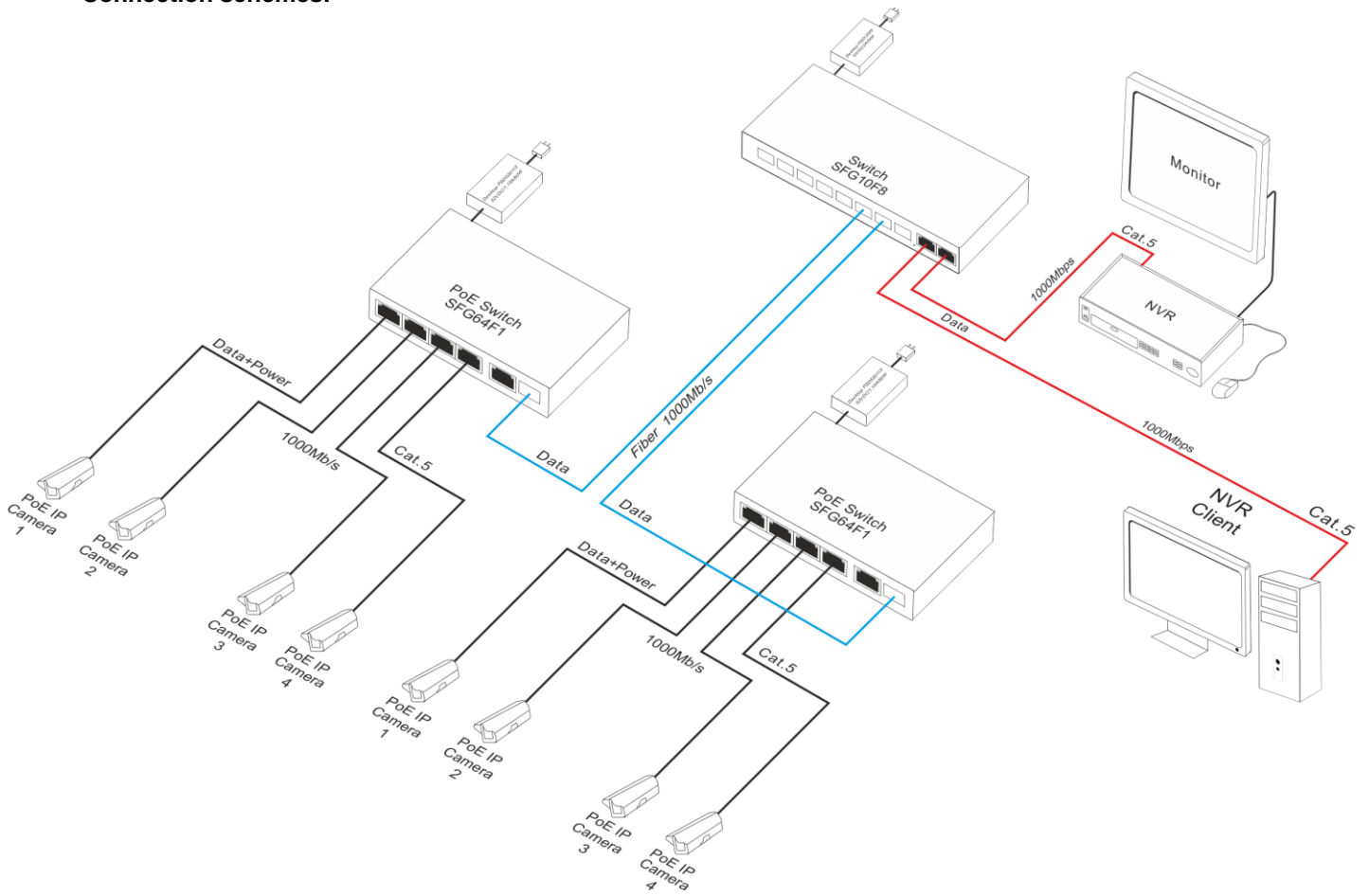

3. Operation indication.

Table 3. Operation indication



OPTICAL INDICATION OF THE SWITCH'S POWER SUPPLY

<p>GREEN LED LIGHT (Power) Indication of the switch's power supply</p>	<p>PWR ●</p>	<p>OFF – no power supply of the switch ON – power supply on, normal operation</p>
---	---------------------	---

OPTICAL INDICATION AT THE SFP PORTS (1÷8)

<p>GREEN LED LIGHT (SFP) The connection status of LAN devices and data transmission</p>	<p>LINK ●</p>	<p>OFF – no connection ON – the device is connected Blinking – data transmission</p>
--	----------------------	---

OPTICAL INDICATION AT THE UP LINK PORTS

<p>GREEN LED LIGHT</p>		<p>OFF – no connection/ the device is connected 10/100 Mb/s ON – the device is connected 1000 Mb/s</p>
<p>YELLOW LED LIGHT (LINK) The connection status of LAN devices and data transmission</p>		<p>OFF – no connection ON – the device is connected 10/100/1000 Mb/s Blinking – data transmission</p>



WEEE LABEL

Waste electrical and electronic equipment must not be disposed of with normal household waste. According to the European Union WEEE Directive, waste electrical and electronic equipment should be disposed of separately from normal household waste.

Pulsar sp. j.

Siedlec 150, 32-744 Łapczyca, Poland

Tel. (+48) 14-610-19-45

e-mail: sales@pulsar.pl

http:// www.pulsar.pl

