

1. Intended use:

The RACK 19" cabinet enables integrating CCTV, AC, I&HAS, RTV, LAN, or other systems in small companies or households. It is intended for devices manufactured in enclosures of the 19" standard. Due to the RACK cabinets, the devices are aesthetically mounted and protected against mechanical damage.

2. Specifications:

| SPECIFICATIONS | |
|-----------------------------|---|
| Mounting dimensions: | W=19", H=15U |
| External dimensions: | W=630, H=770, D=630 [mm, +/-2] |
| Net/gross weight: | 29,2 / 31,2 [kg] |
| Materials: | <ul style="list-style-type: none"> - RACK mounting rails: cold-rolled steel SPCC 1,5mm RAL 9004 - bolted - frame: cold-rolled steel SPCC 1,2mm RAL 9004 - welded - front door: 5mm toughened glass / SPCC 1,2mm RAL 9004 - hinged - side panels: cold-rolled steel SPCC 1,2mm RAL 9004 - removable |
| Static load: | 60 kg |
| Use: | inside, IP20 |
| Notes: | <ul style="list-style-type: none"> - adjustable distance between front and rear RACK rails - ventilation holes in the top and bottom panel - possible mounting of 1 or 2 fans in the top panel - RAW1 / RAW2 - cable ducts in the rear, top and bottom panel - wall-mounting - 4 bolts (not included) - lockable front door (2 keys included) - side panels - lock assembly possible - RAZB16 - fully assembled |
| Certificates, declarations: | RoHS |

3. Structure of the cabinet.

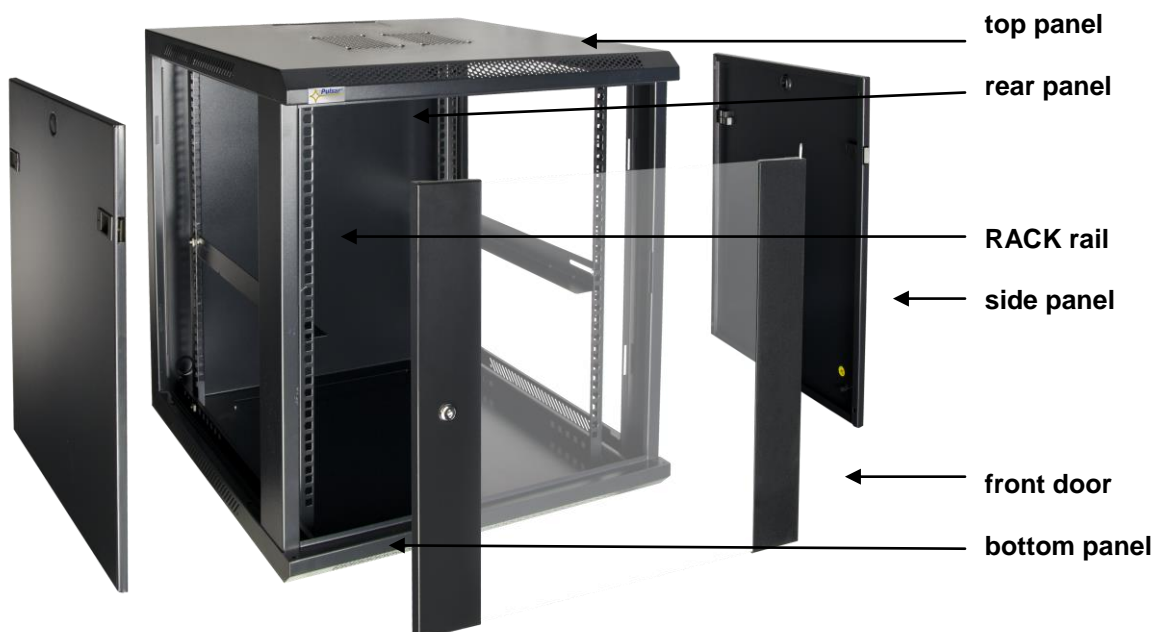

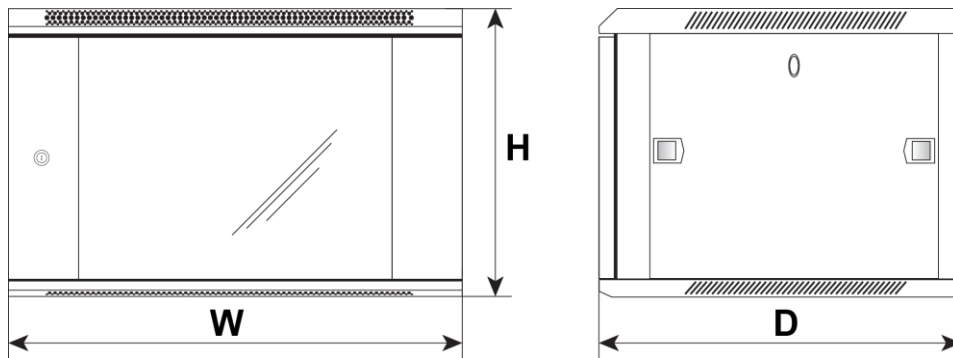

MANUFACTURER

Pulsar

Siedlec 150,

32-744 Łapczyca

Tel. 14-610-19-40, Fax. 14-610-19-50

e-mail: biuro@pulsar.pl, sales@pulsar.pl

http:// www.pulsar.pl, www.zasilacze.pl

WARRANTY

12 months from the date of purchase.

THE WARRANTY IS VALID only upon presentation of the item's proof of purchase.