



# **RAC24P**

v.1.0

## **RAC 24VAC/8x1A/PTC**

**RACK mounted power supply for up to 8 cameras with galvanic isolation.**

**EN**

Edition: 1 from 28.01.2016

Supersedes the edition: -----



### Cechy zasilacza:

- power output 8x1A/24V AC for powering analog cameras ( $\Sigma I=8A$  max.)
- 8 independent, galvanically separated outputs protected by PTC 1A polymer fuses
- supply voltage 230V AC
- LED optical indication LED: AC, TEMP, ALARM, AUX1 ÷ AUX8
- acoustic indication of failure
- control of voltage presence at the AUX1 ÷ AUX8 outputs
- the ALARM technical output of collective failure – relay type, activated by:
  - 230V AC power loss
  - activation of the output fuse in the camera power supply circuit
  - too high temperature of the PSU (>70°C)
- protections:
  - SCP short-circuit protection
  - transformer overheat protection OHP
  - overvoltage protection
  - overload protection OLP
- forced cooling (fan)
- warranty – 2 year from the production date

### Sample application of the RACK power supply unit.

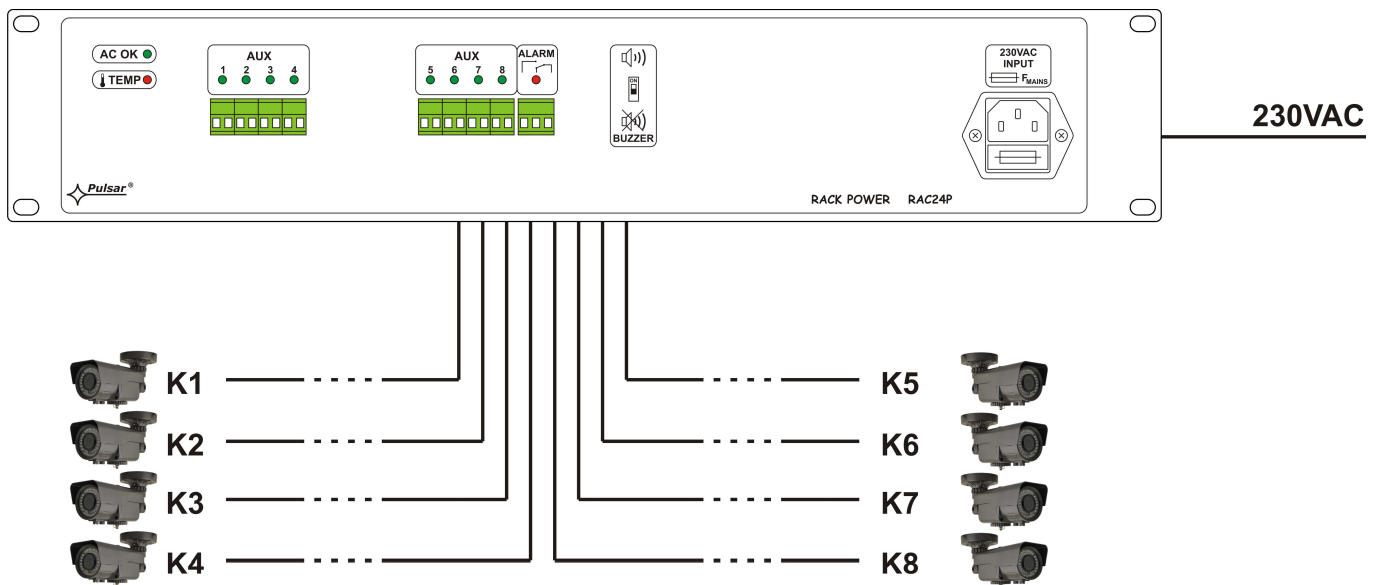

### CONTENTS:

1. Technical description.
  - 1.1. General description
  - 1.2. Block diagram
  - 1.3. Description of PSU components and connectors
  - 1.4. Specifications
2. Installation.
  - 2.1. Requirements
  - 2.2. Installation procedure
3. Operating status indication.
  - 3.1. LED indication
  - 3.2. Technical output
  - 3.3. Acoustic indication
4. Operation and use.
  - 4.1. Overload or short circuit of the PSU output
  - 4.2. Maintenance

### 1. Technical description.

#### 1.1. General description.

The RAC24P power supply unit is designed for supplying up to 8 analog cameras requiring voltage of 24V AC and the total current capacity of 8A. The PSU has 8 independent, galvanically separated outputs protected by PTC 1A polymer fuses. The power supply is fitted with the ALARM output of collective failure. In case of failure, relay contacts are switched automatically (the corresponding led goes on). The power supply is located in an enclosure adapted for mounting in standard RACK 19" cabinets.

1.2. Block diagram.

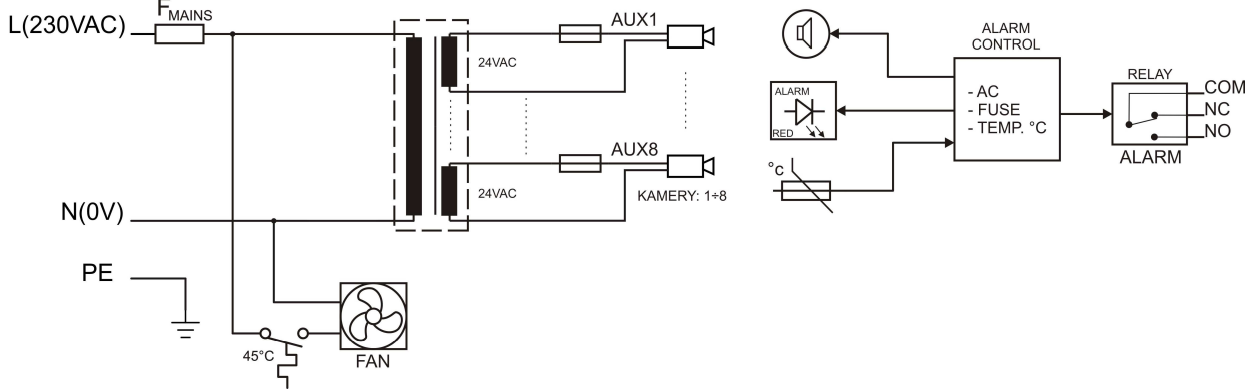



Fig.1. The block diagram of the PSU.

1.3. Description of PSU components and connectors.

Table 1. Components of the front panel of the power supply.

Element no. [Fig. 2]	Description
①	AC OK – green LED, indicating the presence of 230V voltage
②	TEMP – red LED, indicating too high temperature of the power supply (>70°C)
③	Green LED AUX1 ÷ AUX8 – voltage indication at the AUX outputs
④	LED ALARM – red LED failure indication
⑤	AUX1 ÷ AUX8 – independently protected outputs
⑥	ALARM – technical output of collective failure – relay
⑦	BUZZER, micro switch, turning ON / OFF of acoustic indication  switch in the top position, indication ON  switch in the down position, indication OFF
⑧	230V AC INPUT, power socket 230V AC, power cable 1,5m included
⑨	F <sub>MAINS</sub> , fuse in the supply circuit 230V AC, T 6,3A/250V

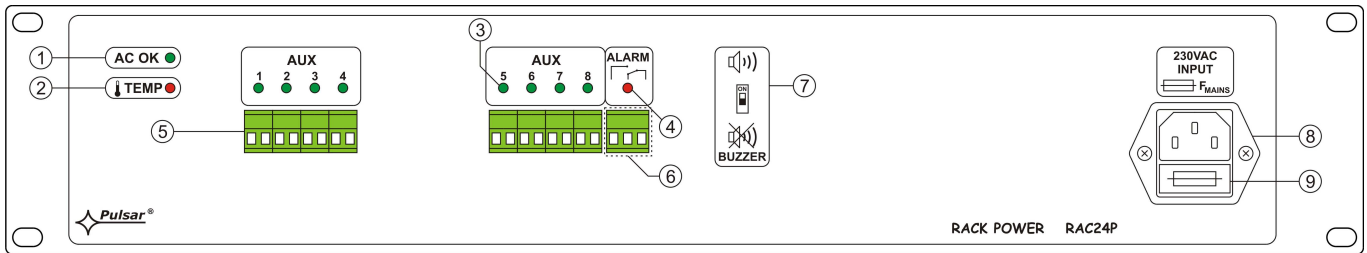

Fig. 2. The front power of the power supply unit.

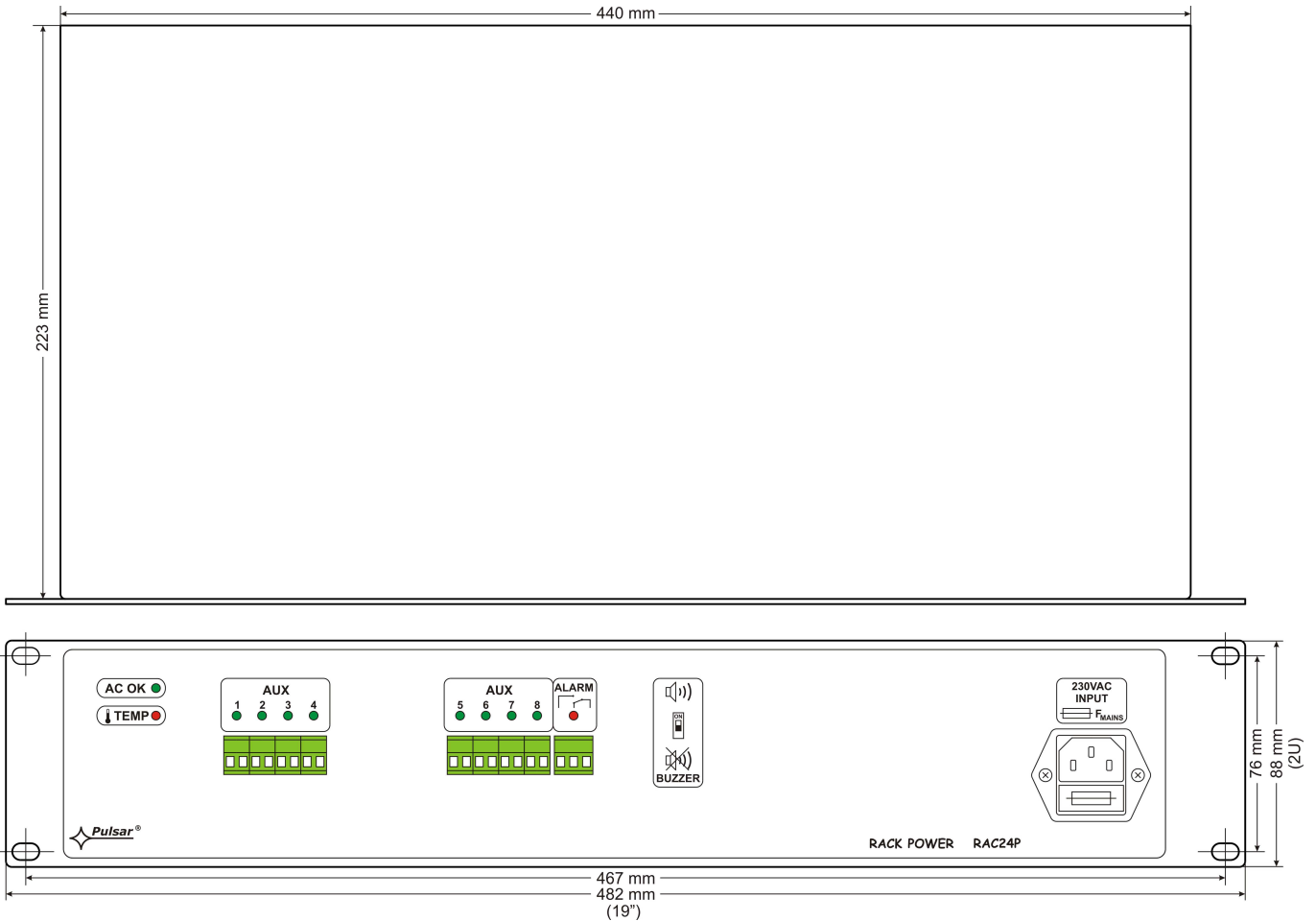

Fig.3. The view of the PSU.

**1.4. Specifications.**

- electrical parameters (tab.2)
- mechanical parameters (tab.3)
- operation safety (tab.4)
- operating parameters (tab.5)

**Electrical parameters (tab. 2).**

Mains supply	195÷253V AC
Current up to	1A@230V AC max.
Supply power S	192VA max.
Output voltage	24V AC (+/-15%)
Output current	<b>8 x 1 A (Σ I = 8A) max. @24V AC</b>
Short-circuit protection SCP	8 x PTC 1A, polymer fuse
Overload protection OLP	8 x PTC 1A, polymer fuse
Surge protection	varistors
Overheat protection OHP	internal transformer
Optical indication of operation:	LED: AC, TEMP, ALARM, AUX1÷AUX8
Acoustic operation indication:	Piezoelectric indicator ~75dB/0,3m
The ALARM technical output of collective failure	Relay type: 1A @ 30VDC/50VAC
The F <sub>MAINS</sub> fuse in the 230V power supply circuit	T 6,3A

**Mechanical parameters (tab. 3).**

Enclosure dimensions	W=19", H=2U; 482 x 88 x 223 mm (WxHxD)
Fixation	four-point butt mounting to RACK profiles – the set include 4 M6 screws + cage nuts
Net weight	8,10kg / 8,50kg
Enclosure	Steel plate RAL 9005, black
Connectors	230V AC input: the IEC C14 socket with a fuse, power cable 1,5m (included) Outputs: ALARM, AUX1÷AUX8: Φ0,5-2,1 (AWG 24-12) 0,5-1,5mm <sup>2</sup>
Notes	Forced cooling (fan).

**Operation safety (tab.4).**

Protection class PN-EN 60950-1:2007	I (first)
Protection grade PN-EN 60529: 2002 (U)	IP20
Electrical strength of insulation: - between input and output circuits of the PSU (I/P-O/P) - between input circuit and PE protection circuit (I/P-FG) - between output circuit and PE protection circuit (O/P-FG)	3000 V/AC min. 1500 V/AC min. 500 V/AC min.
Insulation resistance: - between input circuit and output or protection circuit	100 MΩ, 500V/DC

**Operating parameters (tab.5).**

Environmental class	II
Operating temperature	-10°C...+45°C
Storage temperature	-20°C...+60°C
Relative humidity	20%...90%, without condensation
Vibrations during operation	unacceptable
Impulse waves during operation	unacceptable
Direct insulation	unacceptable
Vibrations and impulse waves during transport	According to PN-83/T-42106

**2. Installation.**

**2.1. Requirements.**

The PSU RACK shall be mounted by a qualified installer with appropriate permissions and qualifications for 230V/AC installations and low-voltage installations (required and necessary for a given country). The device shall be mounted in confined spaces, according to the environment class II, with normal air humidity (RH=90% max. without condensation) and the temperature from -10°C do +45°C.



**During normal operation the total current consumption of the receivers cannot exceed I=8A.**

As the PSU is designed for a continuous operation and is not equipped with a power-switch, therefore an appropriate overload protection shall be guaranteed in the power supply circuit. Moreover, the user shall be informed about the method of unplugging (usually through assigning an appropriate fuse in the fuse-box). The electrical system shall follow valid standards and regulations.

**2.2. Installation procedure.**

- 1. Before installation, cut off the voltage in the 230V power-supply circuit.**
- Mount the power supply in a RACK 19" cabinet as shown below:



- Mount M6 cage nuts



- Secure the enclosure with 4xM6 screws

- Connect the receivers' cables to the terminals AUX1...AUX8.
- If needed, the following technical connections can be made:
  - ALARM – technical output of collective failure
- Connect the ~230V AC power cord with the IEC C13 plug (included) to the 230V AC power supply and turn on the power (~230V).
- Check the PSU operation indicator.

### 3. Operating status indication.

#### 3.1. LED indication.

The PSU has 11 LED lights at the front panel:

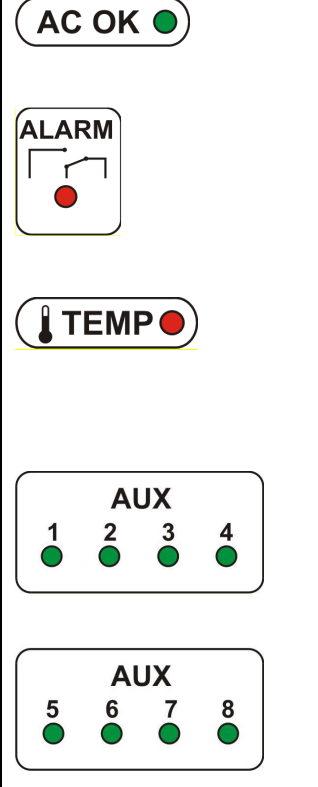
	<p><b>GREEN LED:</b></p> <ul style="list-style-type: none"><li>• on – the PSU is supplied with 230V AC</li><li>• off – no 230V AC supply</li></ul> <p><b>RED LED:</b></p> <ul style="list-style-type: none"><li>• on – failure</li><li>• off – no failure</li></ul> <p><b>RED LED:</b></p> <ul style="list-style-type: none"><li>• ON – too high temperature of the power supply (&gt;70°C)</li><li>• OFF – standard temperature of the power supply</li></ul> <p><b>GREEN LED:</b></p> <ul style="list-style-type: none"><li>• on – DC voltage in the AUX1...AUX8 output</li><li>• off – no DC voltage in the AUX1...AUX8 output</li></ul>
--	---

#### 3.2. Technical output.

The power supply is fitted with the **ALARM** output of collective failure (relay type). A collective failure can be triggered by the following events:

- 230V AC mains power failure
- Activation of the PTC polymer fuse in the camera power supply circuits
- Too high temperature of the power supply (>70°C)

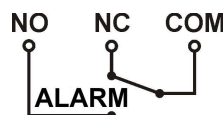



Fig. 4. Electrical diagram of the ALARM collective output of failure.



**CAUTION!** In Fig.4 the set of contacts shows a potential-free status of the relay, which corresponds to power supply failure.

### 3.3. Acoustic indication.

A collective failure is indicated by the piezoelectric indicator, 1 beep every second. The acoustic indication can be turned off by changing the ON / OFF position of the switch .



switch in the up position, indication ON



switch in the down position, indication OFF

## 4. Operation and use.

### 4.1. Overload or short circuit of the PSU output.

The AUX1 ÷ AUX8 power supply outputs are protected against short-circuit with PTC 1A polymer fuses. In the case of fuse activation, disconnect the load from the power supply output for approximately 1 minute.

### 4.2. Maintenance.

Any and all maintenance operations may be performed following the disconnection of the PSU from the power supply network. The PSU does not require performing any specific maintenance measures. In case of fuse replacement, use a replacement of the same parameters.

**WEEE LABEL**

**Waste electrical and electronic equipment must not be disposed of with normal household waste. According to the European Union WEEE Directive, waste electrical and electronic equipment should be disposed of separately from normal household waste.**

**GENERAL WARRANTY CONDITIONS**

1. Pulsar (manufacturer) grants a two-year quality warranty for the equipment, starting from the production date.
2. The warranty includes free-of-charge repair or replacement with an appropriate equivalent (selected by the manufacturer) if the malfunction is due to the manufacturer. It includes manufacturing or material defects, provided that such defects have been reported within the warranty period (point.1).
3. The equipment subjected to warranty should be brought to the place of purchase or directly to the main office of the manufacturer.
4. The warranty applies to complete equipment, accompanied by a properly filled warranty claim with a description of the defect.
5. Should the claim be accepted, the manufacturer is obliged to provide warranty repairs, at the earliest convenience, however not later than within 14 days from the delivery to the service centre of the manufacturer.
6. The repair period mentioned in point 5 may be prolonged, if there are no technical possibilities to carry out the repairs, or if the equipment has been conditionally accepted, due to the breaking warranty terms by the claimant.
7. All the services are carried out at the service centre of the manufacturer, exclusively.
8. The warranty does not cover the defects of the equipment, resulting from:
  - reasons beyond the manufacturer's control,
  - mechanical damage,
  - improper storage and transport,
  - use that violates the operation manual or equipment's intended use
  - fortuitous events, including lightning discharges, power failures, fire, flood, high temperatures and chemical agents,
  - improper installation and configuration (failure to follow instruction).
9. The warranty is void in case of construction changes and repairs carried out by any unauthorized service center or in case of damage or modifications to warranty stickers and serial numbers.
10. The liability of the manufacturer towards the buyer is limited to the value of the equipment determined according to the wholesale prices suggested by the manufacturer on the day of purchase.
11. The manufacturer takes no responsibility for the defects that result from the damaging, malfunctioning or inability to operate the equipment especially when resulting from failure to comply with the recommendations and requirements contained in the manual.

**Pulsar**

Siedlec 150, 32-744 Łapczyca, Polska  
Tel. (+48) 14-610-19-40, Fax. (+48) 14-610-19-50  
e-mail: [biuro@pulsar.pl](mailto:biuro@pulsar.pl), [sales@pulsar.pl](mailto:sales@pulsar.pl)  
http:// [www.pulsar.pl](http://www.pulsar.pl), [www.zasilacze.pl](http://www.zasilacze.pl)