



DCDC10H 12V/1A/55MM DC/DC converter



Edition: 5 from 10.06.2014
Supersedes edition: 4 from 01.04.2014

EN

Features:

- Power output 1A/12VDC*
- protections:
- DC power supply range 18÷40V DC
- against short circuit protection SCP
- high efficiency 87%
- overload protection OLP
- IP 67 enclosure
- against reverse input voltage polarity
- warranty – 2 year from the production date

1. Technical description.

1.1. General description.

The DCDC converter is used for powering devices that require stabilized voltage of **12V DC**. The maximum current load is **1A* (Pmax= 12W)**. This module does not have galvanic insulation between the input and output (IN-AUX), and operates on a common ground potential. The unit is protected against short circuit, overload and against reverse input voltage polarity.

1.2. Specifications.

Supply voltage	18 ÷40V DC
Supply power	12W max.
Efficiency	87%
Output voltage	12V DC
Current consumption by converter systems	10mA max.
Output current $t_{AMB}<30^{\circ}C$	1A - refer to chart 1.
Output current $t_{AMB}=40^{\circ}C$	0,7A - refer to chart 1.
Ripple voltage	100mV p-p max.
Protection against short circuits (SCP) and overloads (OLP)	200% ÷ 400% of module power – output power limit, automatic return after elimination of short circuit
IP protection class	IP67
Operating conditions	temperature $-10^{\circ}C \div +40^{\circ}C$ relative humidity 20%...90%
Dimensions (LxWxH)	50 x 48 x 25 [mm]
Net/gross weight	0,10kg / 0,13kg
Length of DC input cable	0,3m
Length of DC output cable	0,5m + plug DC5,5/2,1 female
Storage temperature	$-20^{\circ}C \dots +60^{\circ}C$

* In order to extend the life of the converter, the load current of 0,7A is recommended.

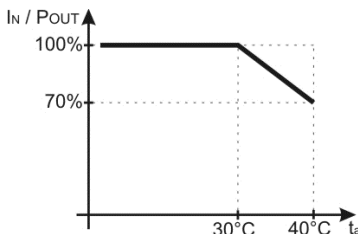

Chart 1.
Relation between output current and ambient temperature (instantaneous load).

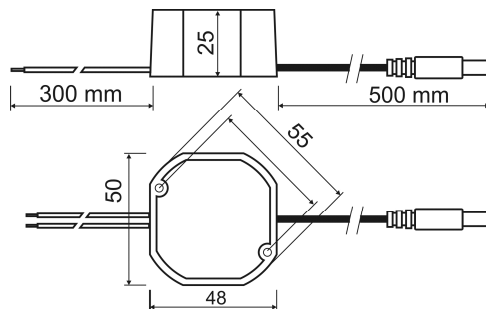

Fig. 1. Mechanical view and dimensions of the converter.

* Refer to chart 1

1.3. Accessories.

For the converters are available accessories - cable adapter. For details –visit www.pulsar.pl.

2. Installation.

2.1. Requirements.

The converter shall be mounted by the qualified installer having appropriate (required and necessary for a given country) permissions and qualifications for connecting (operating) low-voltage installations. The unit should be mounted in confined spaces, in accordance with the 2nd environmental class, with normal relative humidity (RH=90% maximum, without condensation) and temperature from -10°C to +40°C.

In order to meet the LVD and EMC requirements, the rules concerning: supply, development and shielding ought to be followed - accordingly to the application.

2.2. Installation procedure.

1. Fit the converter inside the device.
2. Connect the converter input cables to the DC voltage source, according to polarity.
3. Connect the converter output cables to the load.
4. After the performance of test and function checks, close the case, cabinet, etc.

3. Maintenance.

Any and all maintenance operations may be performed following the disconnection of the converter from the power network. The converter does not require any specific maintenance procedures, however, in the case of significant level of dust, it should be cleaned with compressed air.



WEEE marking

According to the EU WEE Directive – It is required not to dispose of electric or electronic waste as unsorted municipal waste and to collect such WEEE separately.

GENERAL WARRANTY CONDITIONS

1. Pulsar K. Bogusz Sp.j. (the manufacturer) grants a two-year warranty for the equipment, counted from the device's production date.
2. The warranty includes free-of-charge repair or replacement with an appropriate equivalent (the selection is at the manufacturer's discretion) if the malfunction is due to the manufacturer, includes manufacturing or material defects, unless such defects have been reported within the warranty period (item 1).
3. The equipment subject to warranty is to be brought to the place where it was purchased, or directly to the main office of the manufacturer.
4. The warranty applies to complete equipment, accompanied by a properly filled warranty claim with a description of the defect.
5. Should the claim be accepted, the manufacturer is obliged to provide warranty repairs, at the earliest convenience, however not later than within 14 days from the delivery to the service centre of the manufacturer.
6. The repair period mentioned in item 5 may be prolonged, if there are no technical possibilities to carry out the repairs, or if the equipment has been conditionally accepted, due to the breaking warranty terms by the claimant.
7. All the services rendered by force of the warranty are carried out at the service centre of the manufacturer, exclusively.
8. The warranty does not cover the defects of the equipment, resulting from:
 - reasons beyond the manufacturer's control,
 - mechanical damage,
 - improper storage and transport,
 - use that violates the operation manual or equipment's intended use
 - fortuitous events, including lightning discharges, power failures, fire, flood, high temperatures and chemical agents,
 - improper installation and configuration (in defiance with the manual),
9. The warranty is void in any of the following circumstances:
 - construction changes
 - repairs carried out by any unauthorized service center
 - damage or removal of warranty labels
 - modifications of the serial number
10. The liability of the manufacturer towards the buyer is limited to the value of the equipment, determined according to the wholesale prices suggested by the manufacturer on the day of purchase.
11. The manufacturer takes no responsibility for the defects that result from:
 - the damaging, malfunctioning or inability to operate the equipment
 - defects that result from using the equipment outside its stated specifications and operating specifications failing to abide by the recommendations and requirements contained in the manual, or the use of the equipment.

Pulsar K.Bogusz Sp.j.

Siedlec 150, 32-744 Łapczyca, Poland
Tel. (+48) 14-610-19-40, Fax. (+48) 14-610-19-50
e-mail: biuro@pulsar.pl, sales@pulsar.pl
http:// www.pulsar.pl, www.zasilacze.pl